

SITEX® FL

Description

The SITEX® FL couplings are designed for optimizing the connections between Diesel engines and hydraulic pumps (hydrostatic transmissions). They consist of a Polyamid flange, reinforced by fibreglass, with high mechanical strength and dimensional stability with temperature, complete with a toothed

steel hub.

The special teeth allows SITEX® FL couplings to compensate for small misalignments thus avoiding wear.

The steel-Polyamide coupling allows maintenance free continuous operation.

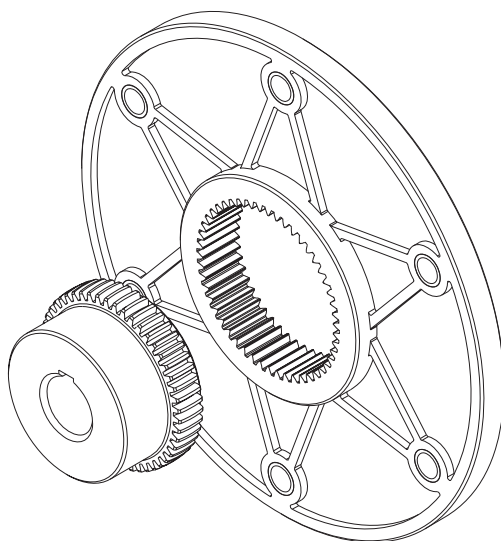

2. Main characteristics and advantages

Minimum dimensions: The whole coupling length is usually installed inside the engine housing, reducing the axial dimension to a minimum. This way less tools are required for fitting.

Axial misalignments: The hub teething can move freely axially inside the Polyamid flange avoiding axial forces which may arise on the pump shaft.

Heat stability: The special fiberglass Polyamid flange is designed to operate in internal combustion engine environments without air cooling and up to 140° C.

Maintenance free: The SITEX® FL joints are maintenance and lubrication free.

Quick assembling: The blind assembly makes the SITEX® FL assembly and inspection very fast.

Angular misalignments: The special teeth allow angular misalignment correction, protecting the bearings against angular forces.

Stiffness: The SITEX® FL couplings are stiff couplings: Operations will be torsionally vibration free.

The SITEX® FL couplings are used in connections between the flywheels of the internal combustion engines and: hydro-pumps, rotating pistons, and compressor blades.



Flange dimensions in accordance with SAE J620

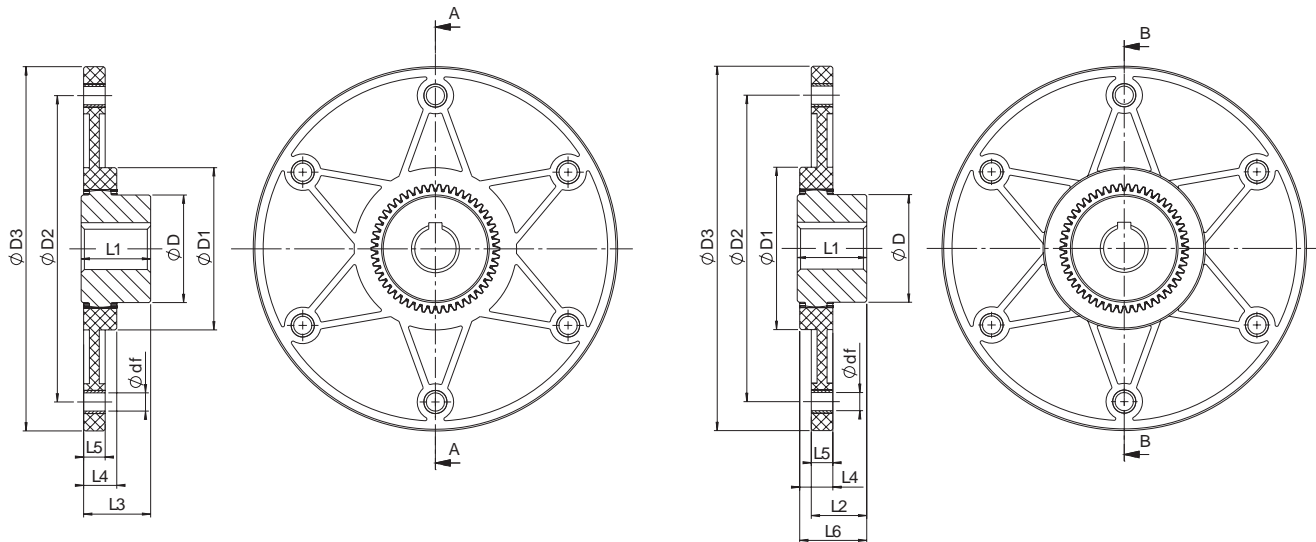

SAE flange size	Dimensions [mm]											
	Max. bore	D	D1	D2	D3	df x z	L1	L2	L3	L4	L5	L6
GDF 42 FL 6 1/2"	42	65	100	200,02	215,9	9 x 6	42	33	42	20	13	40
GDF 42 FL 7 1/2"	42	65	100	222,25	241,3	9 x 8	42	33	42	20	13	40
GDF 42 FL 8"	42	65	100	244,47	263,52	11 x 6	42	33	42	20	13	40
GDF 42 FL 10"	42	65	100	295,27	314,32	11 x 8	42	33	42	20	13	40
GDF 48 FL 6 1/2"	48	68	100	200,02	215,9	9 x 6	50	41	50	20	13	48
GDF 48 FL 7 1/2"	48	68	100	222,25	241,3	9 x 8	50	41	50	20	13	48
GDF 48 FL 8"	48	68	100	244,47	263,52	11 x 6	50	41	50	20	13	48
GDF 48 FL 10"	48	68	100	295,27	314,32	11 x 8	50	41	50	20	13	48
GDF 48P FL 6 1/2"	48	68	100	200,02	215,9	9 x 6	50	38	45	20	13	46
GDF 48P FL 7 1/2"	48	68	100	222,25	241,3	9 x 8	50	38	45	20	13	46
GDF 48P FL 8"	48	68	100	244,47	263,52	11 x 6	50	38	45	20	13	46
GDF 48P FL 10"	48	68	100	295,27	314,32	11 x 8	50	38	45	20	13	46
GDF 65 FL 8"	65	96	132	244,47	263,52	11 x 6	70	60	69	27	21	66
GDF 65 FL 10"	65	96	132	295,27	314,32	11 x 8	70	60	69	27	21	66
GDF 65 FL 11 1/2"	65	96	132	333,37	352,42	11 x 8	70	60	69	27	21	66
GDF 65P FL 8"	65	96	132	244,47	263,52	11 x 6	70	60	69	27	21	66
GDF 65P FL 10"	65	96	132	295,27	314,32	11 x 8	70	60	69	27	21	66
GDF 65P FL 11 1/2"	65	96	132	333,37	352,42	11 x 8	70	60	69	27	21	66
GDF 80 FL 11 1/2"	80	124	170	333,37	352,42	11 x 8	90	78	87	30	21	87

48P and 65P are for hubs with over-sized toothed band.

Order form

 SITEX® hub
 Type
 Bore
 Long hub
 GDM 12/48 F32
 GDM 12/48 L

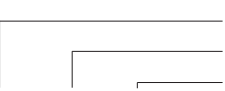

 SITEX® FL flange
 Bore
 SAE flange size
 GDF 65 FL11-1/2

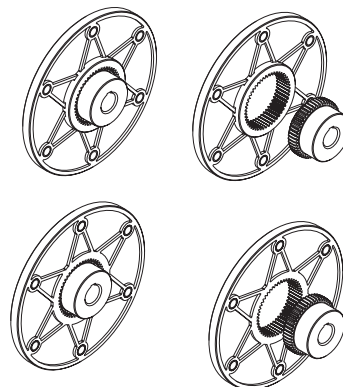
SITEX FL

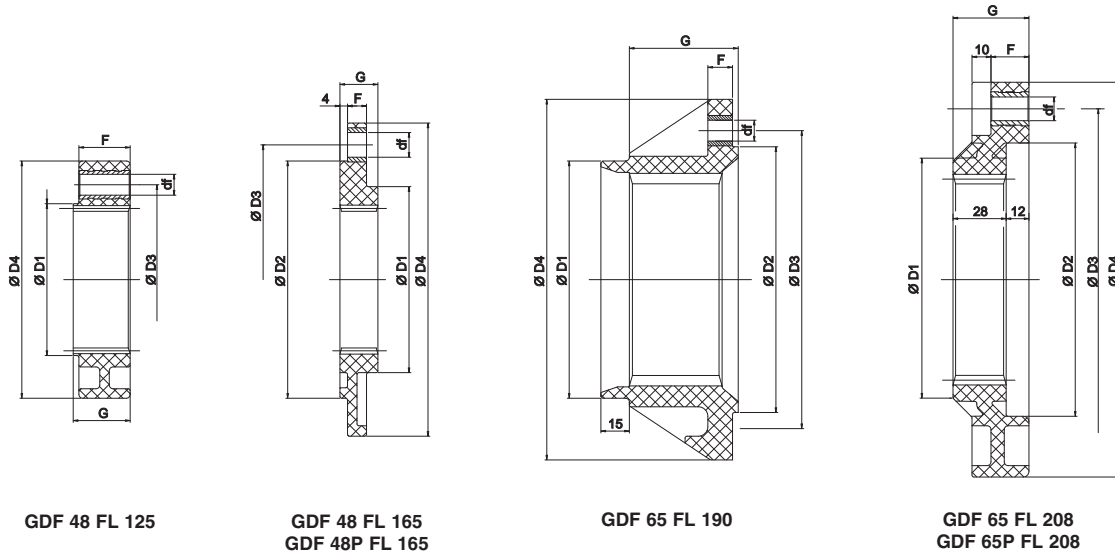

SITEX® FL

Special flange dimensions



Special flange size	Max. bore	D1 [mm]	D2 [mm]	D3 [mm]	D4 [mm]	F [mm]	G [mm]	df x z
GDF 48 FL 125	48	80	-	100	125	27	30	11 x 3
GDF 48 FL 165	48	98	125	142	165	10	20	13 x 6
GDF 48P FL 165	48	98	125	142	165	10	20	13 x 6
GDF 65 FL 190	65	125	140	160	190	13	57	11 x 6
GDF 65 FL 208	65	125	144	180	208	20	40	18 x 8
GDF 65P FL 208	65	125	144	180	208	20	40	18 x 8

Flywheel bellhousing

The dimensions of the flywheel Bellhousing plates are in accordance with SAE 617.

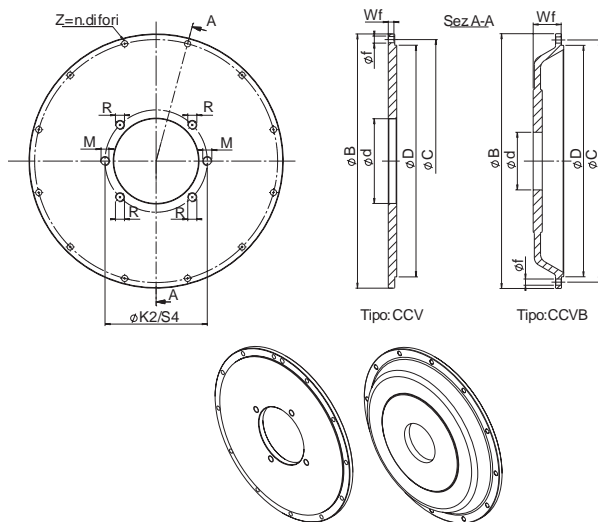

SAE - Flywheel Bellhousing							
SAE type	D [mm]	B [mm]	C [mm]	Number of holes Z	f [mm]	CCV	CCVB
						Wf	Wf
SAE 6	266,7	308	285,8	8	11	10,5	-
SAE 5	314,32	356	333,4	8	11	10,5	25
SAE 4	361,95	403	381	12	11	10,5	35
							50
SAE 3	409,58	451	428,6	12	11	10,5	50
SAE 2	447,68	489	466,7	12	11	14	-

Order form

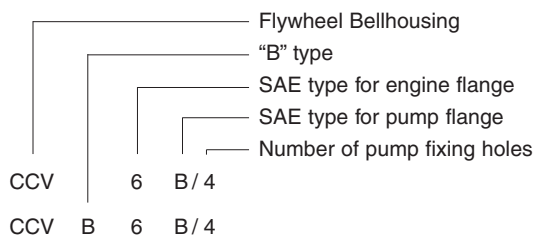

Pump assembling SAE dimensions							
SAE Pump	Center bore d [mm]	Pump fixing holes					
		n. 2 holes		n. 4 holes			
		K2	M	S4	R		
AA	50,8	82,6	M8	5/16"	-	-	-
A	82,55	106,4	M10	3/8"	104,6	M10	3/8"
B	101,6	146	M12	1/2"	127	M12	1/2"
C	127	181	M16	5/8"	162	M12	1/2"
D	152,4	228,6	M16	5/8"	228,6	M16	5/8"

Technical characteristics

Type	Misalignment			Torque			Weight / Moment of inertia						Dynamic torsional rigidity +60°C dampening factor [Ψ] = 0,4 [Nm/rad]				
	Axial [mm]	Angular [°]	Radial [mm]	Nominal T _{KN} [Nm]	Max T _{Kmax} [Nm]	Reversible T _{KW} [Nm]	Hub		SAE SITEX® FL flange								
								6-1/2"	7-1/2"	8"	10"	11-1/2"	0,25 T _{KN}	0,50 T _{KN}	0,75 T _{KN}	1,00 T _{KN}	
8/42	2	1°	0,2	240	600	120	Kg	0,68	0,39	0,455	0,565	0,8	-	33 x 10³	78 x 10³	110 x 10³	130 x 10³
							Kgm²	0,0006	0,003	0,004	0,006	0,011	-				
12/48	2	1°	0,2	250	620	125	Kg	0,75	0,4	0,52	0,5	0,75	-	33 x 10³	78 x 10³	110 x 10³	130 x 10³
							Kgm²	0,0007	0,003	0,004	0,006	0,011	-				
12/48 P	1	1°	0,2	310	780	155	Kg	0,85	0,4	0,52	0,5	0,75	-	38 x 10³	88 x 10³	125 x 10³	148 x 10³
							Kgm²	0,0007	0,003	0,004	0,006	0,011	-				
30/60	2	1°	0,3	660	1650	330	Kg	2,4	-	-	0,8	0,93	1,08	58 x 10³	142 x 10³	205 x 10³	250 x 10³
							Kgm²	0,005	-	-	0,009	0,015	0,023				
30/60 P	1	1°	0,2	800	1950	400	Kg	2,45	-	-	0,8	0,93	1,08	76 x 10³	185 x 10³	270 x 10³	330 x 10³
							Kgm²	0,005	-	-	0,009	0,015	0,023				
40/80	2	1°	0,3	1300	3100	650	Kg	5,1	-	-	-	-	1,13	190 x 10³	420 x 10³	590 x 10³	710 x 10³
							Kgm²	0,015	-	-	-	-	0,023				

SITEX® FL

Selection

For a proper sizing a safety factor $k = 1,3 - 1,6$ must be considered in accordance to the application. Or, the coupling nominal torque must be higher or equal to the engine torque multiplied for k :

$$T_{KN} \geq T_N \cdot k$$

T_{KN} = coupling nominal torque

T_N = engine side torque

k = safety factor selected in accordance with the use

Applications

k factor

Tandem rollers.....	1,6
Asphalt processing machines.....	1,4
Agricultural machines.....	1,4
Fork lift trucks.....	1,6
Concrete Mixer.....	1,3
Self-propelled cranes.....	1,4
Excavators	1,4
Farm tractors.....	1,4
Road working machines.....	1,4

Assembling

The particular versatility of the SITEX® FL couplings allows for several assembling positions and different hub lengths and the ability to obtain the suitable dimension for every application.

1) Center the flange on the fly-wheel in correspondence to the seat and tighten the fixing screws DIN 912 – 8.8 class in accordance with the torque values shown in the table:

Screw	Ms
M 8	25 Nm
M 10	86 Nm
M 12	355 Nm

2) Center the fly-wheel cover plate in relation to the seat on the engine bellhousing. Tighten the screws.

3) Install the toothed hub onto the pump shaft. For split clamp hub, tighten in accordance with the torques shown in the table.

Coupling	Screw	Ms
8/42 - 12/48	M 10	49 Nm
30/60	M 12	86 Nm
40/80	M 16	355 Nm

4) Move the pump-hub assy through the fly-wheel cover plate and up to the stop. Tighten the screws.

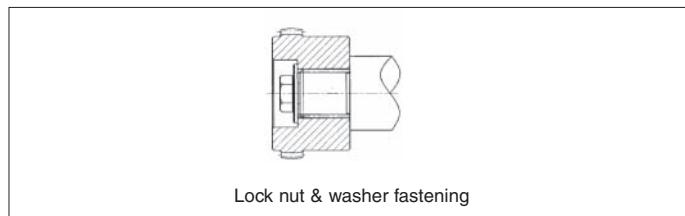
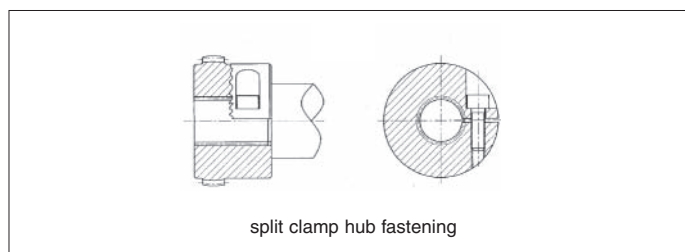
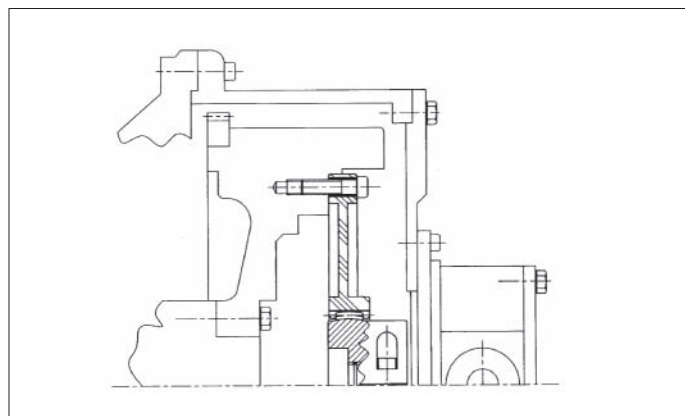

FLD execution

The SITEX® FLD couplings are designed for applications which combine with diesel engines pulley. These couplings allow for belt replacement without pump disassembly. The operating temperature range is from -25°C to 100°C

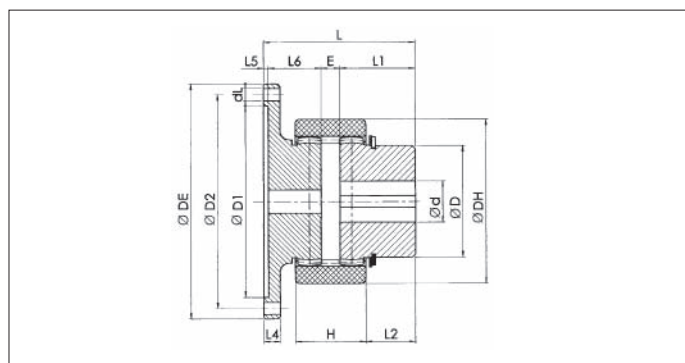

Type	T _{KN} [Nm]	T _{Kmax} [Nm]	T _{KW} [Nm]	d _{max} [mm]	L5 [mm]	L1 [mm]	L4 [mm]	L6 [mm]	E [mm]	L [mm]	H [mm]	L2 [mm]	D [mm]	DH [mm]
35 / 28 FLD	45	90	23	26	4	35,5	10	28,5	13	81	39	22,5	42	70
5 / 32 FLD	60	120	30	30	4	35,5	12	28,5	13	81	40	21,5	48	84
8 / 42 FLD	140	280	70	42	5	37,5	13	30,5	13	86	43	22,5	63	100
30 / 60 FLD	380	780	190	65	5	64	16	44	16	129	60	42	95	140
40 / 80 FLD	700	1400	350	80	6	83	20	53	20	162	69	58,5	120	175

T_{KN} = Nominal Coupling torque T_{Kmax} = Max Coupling torque T_{KW} = Max reversal torque

Splined bore hub

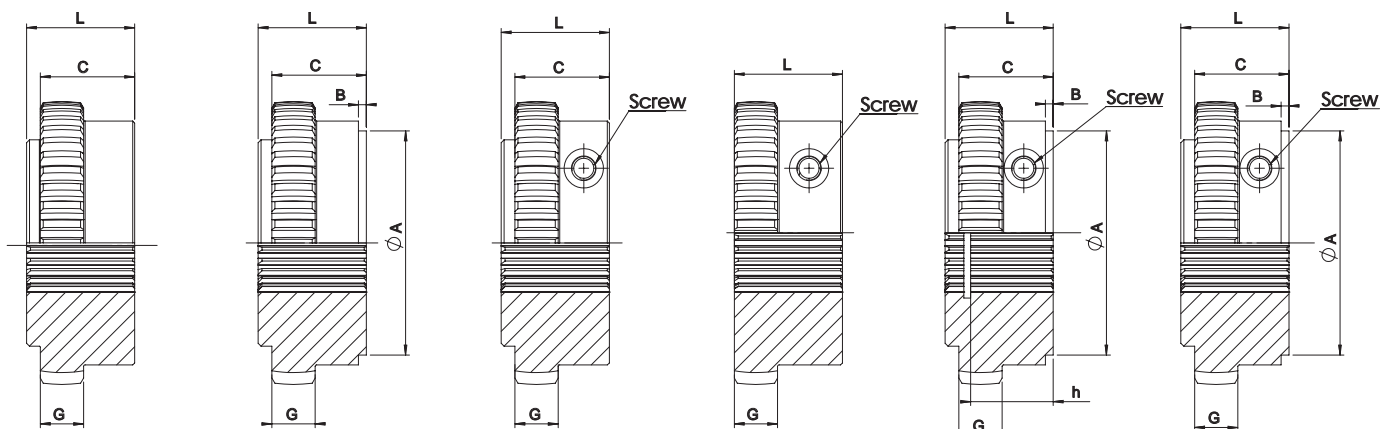

Fig.1 Splined bore hub Fig.2 Splined bore hub Fig.3 Clamping hub with splined bore Fig.4 Clamping hub with splined bore Fig.5 Clamping hub with splined bore and seeger-ring seating Fig.6 Clamping hub with splined bore

SITEX® FL

Hub	Splines DIN 5480									
	Fig.	Splines type	A [mm]	B [mm]	C [mm]	G [mm]	h [mm]	L [mm]	Screw	Ms [Nm]
42	1	25 x 1.25 x 18	-	-	37	13	-	42	-	-
	3	25 x 1.25 x 18	-	-	37	13	-	42	M10	49
	6	30 x 2 x 14	60	6	37	13	-	42	M10	49
48	2	30 x 2 x 14	60	6	45	13	-	50	-	-
	6	30 x 2 x 14	60	6	45	13	-	50	M10	49
65	2	35 x 2 x 16	60	6	49	20	-	55	-	-
	6	35 x 2 x 16	60	6	54	20	-	60	M12	86
	2	40 x 2 x 18	78	6	49	20	-	55	-	-
	6	40 x 2 x 18	78	6	54	20	-	60	M12	86
	6	45 x 2 x 21	78	6	49	20	-	55	M12	86
80	3	50 x 2 x 24	-	-	49	25	-	55	M16	295

Hub	Splines SAE J498											
	Fig.	Splines type	Tooth	DP	A [mm]	B [mm]	C [mm]	h [mm]	G [mm]	L [mm]	Screw	Ms [Nm]
42	3	PH-S 5/8"	9	16/32	-	-	37	-	13	42	M10	49
	4	PI-S 3/4"	11	16/32	-	-	-	-	13	42	M10	49
	6	PB-S 7/8"	13	16/32	60	3	37	-	13	42	M10	49
	5	PB-BS 1"	15	16/32	50	6	37	27	13	42	M10	49
48	5	PA-S 1 3/8"	21	16/32	52	7	45	45	13	50	M10	49
65	5	PA-S 1 3/8"	21	16/32	52	5	49	48	20	55	M12	86
	5	PC-S 1 1/4"	14	12/24	52	5	49	44	20	55	M12	86
80	3	PE 1 3/4"	27	16/32	-	-	49	-	25	55	M16	295

Ms= clamp screws tightening torque
Other splined bores and executions are available upon request.

SITEX® FL coupling selection

Motor side

Engine nominal power [kW]

Number of rotations at nominal power [rpm]

SAE dimension of the engine housing

Engine max torque [Nm]

Number of rotations [rpm]

Engine flywheel dimension

Driven side

Type of the pump shaft (specify splined type, diameter and length)

Type of the pump flange
